

OUT OF THE DARKNESS

Shines

Bulbs **THAT LAST
4 EVER**



The Choice
of

LEADERS

FOR ALL TYPES OF

MOTORCYCLES

**BE BOLD!
BE BRIGHT!
BE SEEN!**

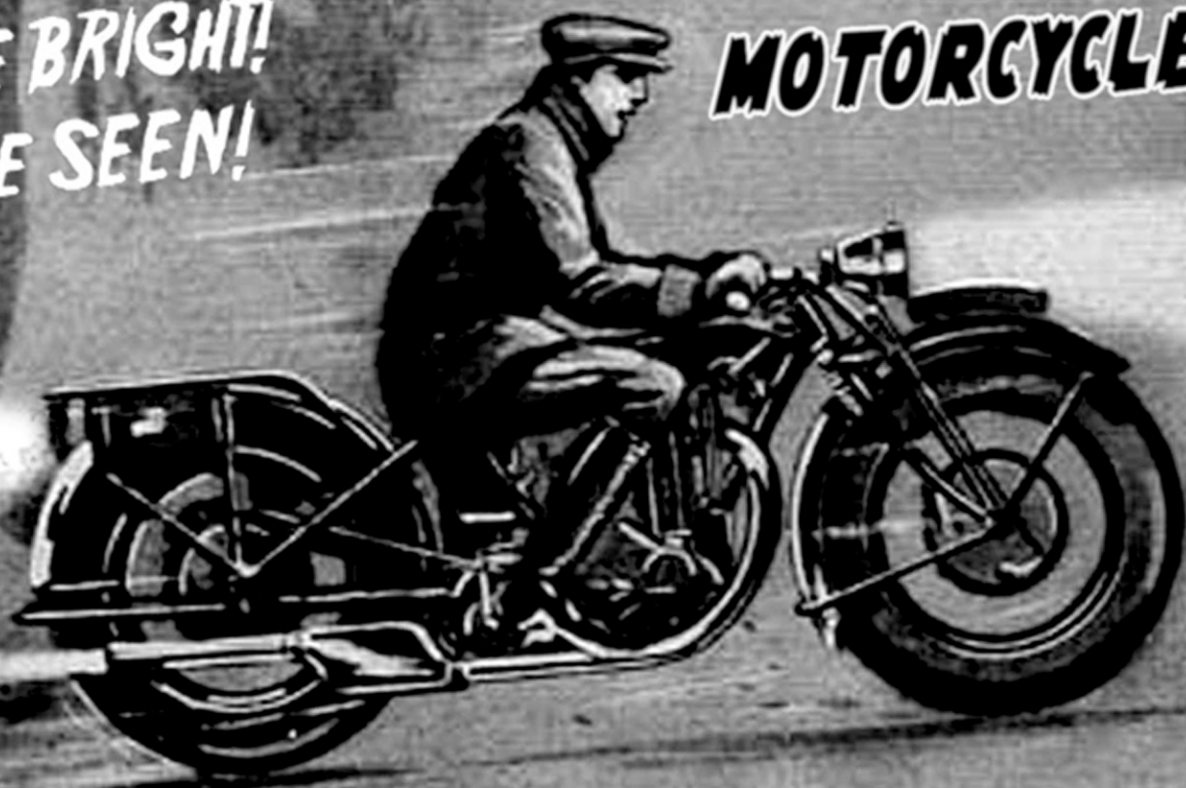

You can pay less elsewhere, but you will not reap the benefits enjoyed by 1000's of satisfied customers. Bulbs That Last 4 Ever utilises the highest quality materials available & is the only constructor that will create a unique lighting system specific to your needs. Visit our website & compare.

The proof is in the Illumination!

www.bulbthatlast4ever.com

LEFT BLANK INTENTIONALLY.

“Lucas style 564” LED Taillight Conversion Kit

INSTALLATION INSTRUCTIONS

Introduction

Thank you for purchasing this LED Conversion Kit for your “Lucas Style 564” Taillight. This Kit has been designed for optimum installation in a reproduction Lucas Style taillight assembly. Installation can also be performed on a genuine “Lucas” taillight assembly; some of the steps outlined here may vary slightly for this type of installation.

When installing your LED Tail Light Conversion Kit, carefully read and follow these installation instructions and make sure to connect wires according to your bike’s electrical system, observing if it has positive or negative grounding. Expect installation to take approximately 30 minutes, utilizing a screwdriver, a pair of wire cutters, and a pair of pliers for crimping wire terminals.

It is recommended that you first remove the taillight from the motorcycle for ease of installation (fig.A) This will help the installation go more smoothly.

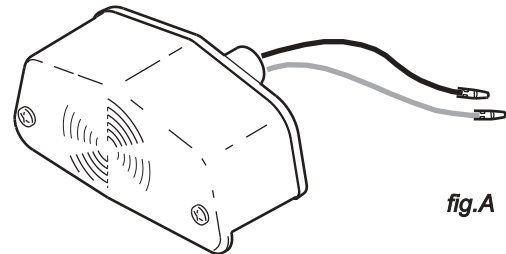

Step 1

Remove the lens, bulb, and...
(fig.B)

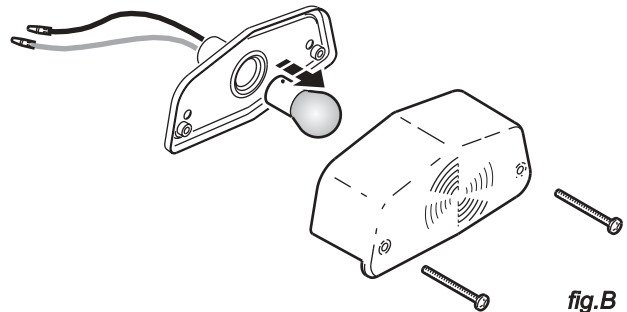

Step 2

... the wire assembly from the taillight reflector plate. (fig.C)

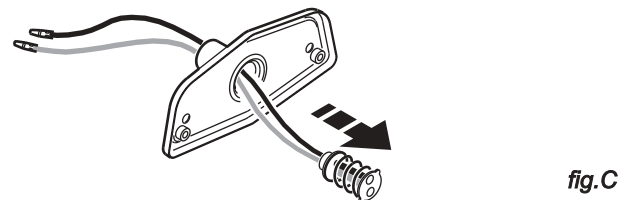

Step 3

Cut the two wires. (fig.D)

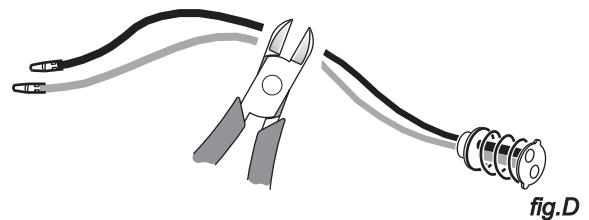

Disclaimer:

Under no circumstances will Bulbthatlast4ever or its representatives be responsible or liable for any incidental or consequential property damage or personal injuries arising from or in connection with the use or installation of any products or devices listed herein.

“Lucas style 564” LED Taillight Conversion Kit

INSTALLATION INSTRUCTIONS

Step 4

Remove the rubber grommet from the wire assembly (fig.E), and...

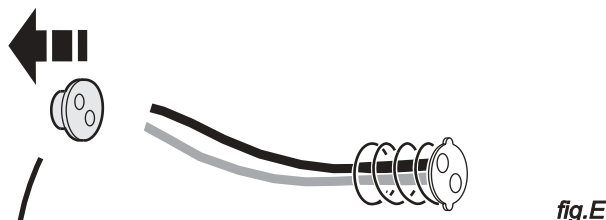

fig.E

Step 5

... carefully insert all 3 wires from your new LED wire assembly into one of the holes in the rubber grommet, and place it approximately 4" (100mm) from the power plug (fig.F). Feeding all 3 wires through one hole is to ensure a tight fit, so the rubber grommet doesn't move once installed.

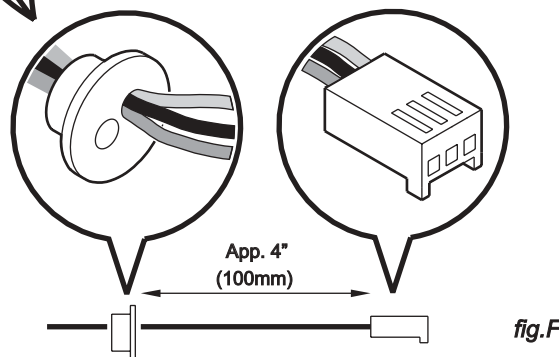

fig.F

Step 6

Now take the LED printed circuit board (PCB) and plug the power cable onto the connector located on the back of the PCB (right-hand side). To make sure connector and wires are not damaged once installed, lightly bend the wires down near the connector end of the cable assembly (fig.G arrow)

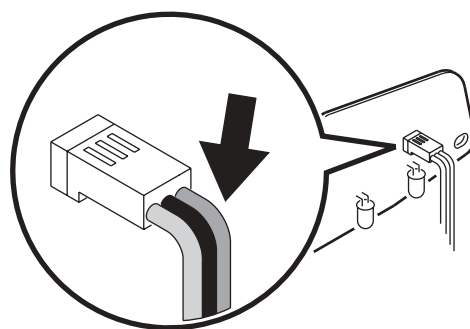

fig.G

Take care to bend the wires and NOT the socket in the PCB.

Disclaimer:

Under no circumstances will Bulbthatlast4ever or its representatives be responsible or liable for any incidental or consequential property damage or personal injuries arising from or in connection with the use or installation of any products or devices listed herein.

“Lucas style 564” LED Taillight Conversion Kit

INSTALLATION INSTRUCTIONS

Step 7

6-VOLT APPLICATIONS ONLY!!

If you have a 6-volt system, locate the jumper on the back of the PCB, and make sure that the jumper setting matches the ground polarity of your bike.

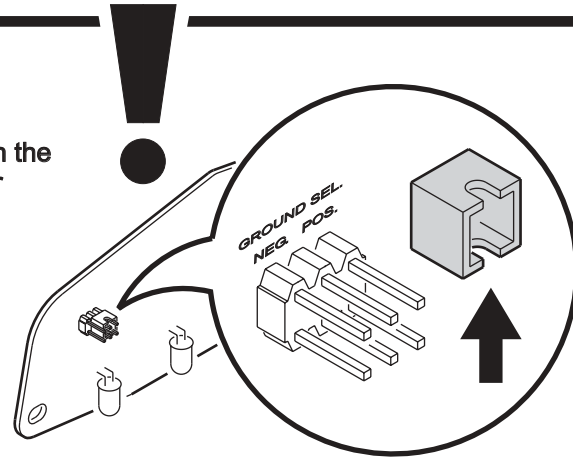
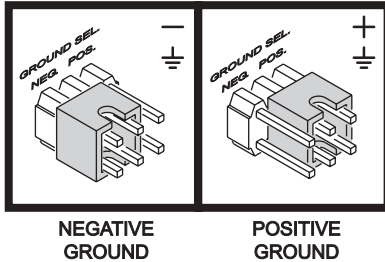

fig.H

Step 8

Insert the 2 screws into the lens, place the PCB, washers and springs from your LED kit on the screws in the lens (fig.I), and...

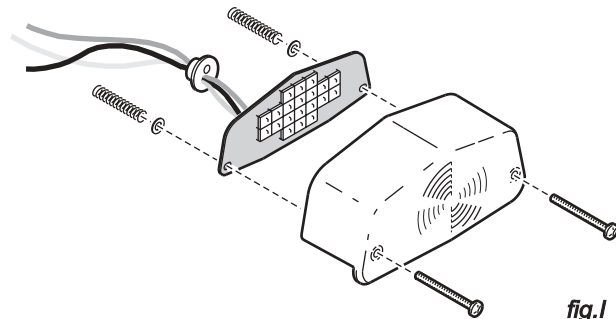

fig.I

Step 9

...feed the wires from the cable assembly into the bulb socket of the taillight reflector plate. Once the rubber grommet has lightly seated against the bulb socket, position the lens so that both mounting screws are correctly aligned and then tighten (fig.J). Do not overtighten.

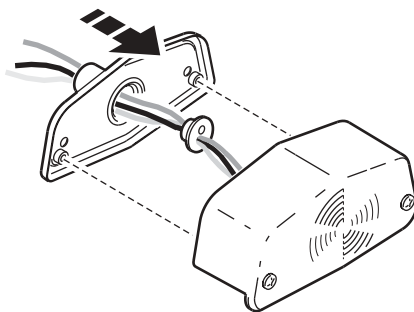

fig.J

Step 10

Now cut the wires to your bike's required length, install and crimp the supplied bullet connectors on the wires according to the table below. Your LED Taillight is now ready to be mounted and connected to motorcycle's wiring. (fig.K)

Wire color	Function	Connector	Shown as
White	Brake Light	Bullet	
Brown	Running Light	Bullet	
Green	Ground	Ring terminal	

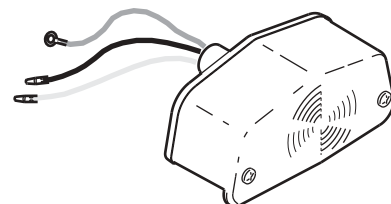

fig.K

Disclaimer:

Under no circumstances will Bulbthatlast4ever or its representatives be responsible or liable for any incidental or consequential property damage or personal injuries arising from or in connection with the use or installation of any products or devices listed herein.



Product Warranty Agreement:

Bulbthatlast4ever warrants all our products, standard, custom, or otherwise against defects in material or workmanship as follows:

1. For a period of 365 days from the date of purchase if this Product is determined to be defective, Bulbthatlast4ever will repair the Product at no charge. After the 365 days period, you must pay a \$10 "Evaluation Charge", labor rate of \$15 per hour, and cost of replacement components. This warranty does not cover cost incurred in connection with the use of un-approved aftermarket accessories used with this Product.
2. To obtain warranty service, you must fill out a "Request for Repair" Form available on-line at <http://www.bulbthatlast4ever.com/returns.html> or call our Help Line at (1) 818-239-2683 for a "Return Merchandise Authorization" number and deliver the Product freight prepaid, in either its original packaging or packing affording an equal degree of protection, to Bulbthatlast4ever as per the information provided on the "Request for Repair" form or provided to you over the phone.

This warranty does not cover the following items listed herein, any implications of following items "WILL VOID" the Product warranty immediately and indefinitely, but are not limited to the listed below:

- Cosmetic damage or damage due to acts of God, accident, misuse, abuse, negligence, commercial use, improper use or maintenance, connection to improper voltage supply, or attempted repair by anyone other than a facility authorized by Bulbthatlast4ever to service this Product.
- Unauthorized customer or end-user modifications, such as grinding, filing, cutting, drilling, or by any other mechanical means with intent to alter the shape or size of the printed circuit board assembly/ies.
- Installation of non-factory approved replacement parts soldered into the printed board assembly/ies such as but not limited to resistors, LEDs, headers, or any other electronic component active or passive used in or on our products. In the case of printed circuit board assembly/ies with factory omitted components, inserting and soldering components or anything into these locations.
- Improper handling of Class I or Class II ESD (Electro-Static Discharge) rated components as per the individual component manufactures handling procedures or datasheet.
- Any damage received to any of the electrical pathways (traces) of the printed circuit board assembly/ies by one more but not limited to the following means, electrical overload, mechanical interference, environmental conditions, deliberate damage inflicted by human or any man-made machine, and/or improper installation of the product.
- Any damage received to the printed circuit board assembly/ies that has resulted due to contact with any type of liquid or fluid, natural or otherwise, but not limited to the following examples, water (fresh or salt-water), gasoline (petrol), any petroleum based products, solvents or cleaners used outside of the manufacturing process.
- Damages that are sustained by accidental damaged such as being involved in a motor vehicle accident of any kind. Accidental dropping the product onto any surface harder than the printed circuit board assembly/ies or its components.
- Damages that may occur from a vehicle's electrical or charging system that is found not to be properly functional to the manufactures specifications.

Proof of purchase in the form of a bill of sale, receipt invoice, or vendor sales slip which is evidence of that the unit is within the Warranty period must be presented to obtain warranty service.

Bulbthatlast4ever reserves the right to refuse any product warranty based on any reason listed above. Bulbthatlast4ever also reserves the right to honor or refuse any warranty repair for any reason based upon any signs or suspicion of product tampering to the above-mentioned Product.